



Self-Propelled Articulating Booms

Z™ -45/25 & Z™ -45/25J DC/Bi-Energy

Specifications

Models	Z-45/25 DC & Bi		Z-45/25J DC & Bi	
Measurements	US	Metric	US	Metric
Working height maximum*	51 ft 6 in	15.87 m	51 ft 9 in	15.94 m
Platform height maximum	45 ft 6 in	13.87 m	45 ft 9 in	13.94 m
Horizontal reach maximum	25 ft	7.62 m	25 ft 1 in	7.65 m
Up and over clearance maximum	23 ft 1 in	7.04 m	23 ft 1 in	7.04 m
A Platform length	2 ft 6 in	0.76 m	2 ft 6 in	0.76 m
B Platform width	6 ft	1.83 m	6 ft	1.83 m
C Height - stowed	6 ft 7 in	2.00 m	6 ft 7 in	2.00 m
D Length - stowed	18 ft 3 in	5.56 m	22 ft 5 in	6.83 m
E Width	5 ft 10.3 in	1.79 m	5 ft 10.3 in	1.79 m
F Wheelbase	6 ft 8 in	2.03 m	6 ft 8 in	2.03 m
G Ground clearance - center	9.5 in	0.24 m	9.5 in	0.24 m

Productivity

Lift capacity	500 lbs	227 kg	500 lbs	227 kg
Platform rotation	180°		160°	
Vertical jib rotation	—		135°	
Turntable rotation	355° non-continuous		355° non-continuous	
Turntable tailswing	zero		zero	
Drive speed - stowed	3.0 mph	4.8 km/h	3.0 mph	4.8 km/h
Drive speed - raised**	0.61 mph	1.0 km/h	0.61 mph	1.0 km/h
Gradeability - stowed***	30%		30%	
Turning radius - inside	6 ft	1.83 m	6 ft	1.83 m
Turning radius - outside	14 ft	4.27 m	14 ft	4.27 m
Controls	24V DC proportional		24V DC proportional	
Tires	9 x 14.5 in		9 x 14.5 in	

Power

Power source - DC	48V DC (eight 6 V batteries, 350 Ah capacity)			
Power source - Bi-Energy	48V DC (eight 6 V batteries, 350 Ah capacity) with Tier IV Kubota 13.3 hp (9.9 kW) diesel driven alternator			
Auxiliary power unit	24V DC		24V DC	
Hydraulic tank capacity	8 gal	30.3 L	8 gal	30.3 L
Fuel tank capacity- Bi-Energy	9 gal	34.1 L	9 gal	34.1 L

Weight****

DC	15,350 lbs	6,963 kg	16,300	7,394 kg
Bi-Energy	15,850 lbs	7,190 kg	16,800	7,620 kg

Standards Compliance ANSI A92.5, CSA B354.4, EN 280, AS 1418.10

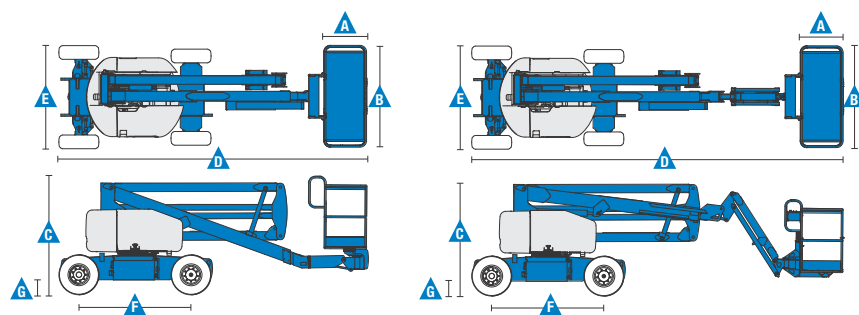

* The metric equivalent of working height adds 2 m to platform height. U.S. adds 6 ft to platform height.

** In lift mode (platform raised), the machine is designed to operate on firm, level surfaces only.

*** Gradeability applies to driving on slopes. See operator's manual for details regarding slope ratings.

**** Weight will vary depending on options and/or country standards.

Range Of Motion Z-45/25

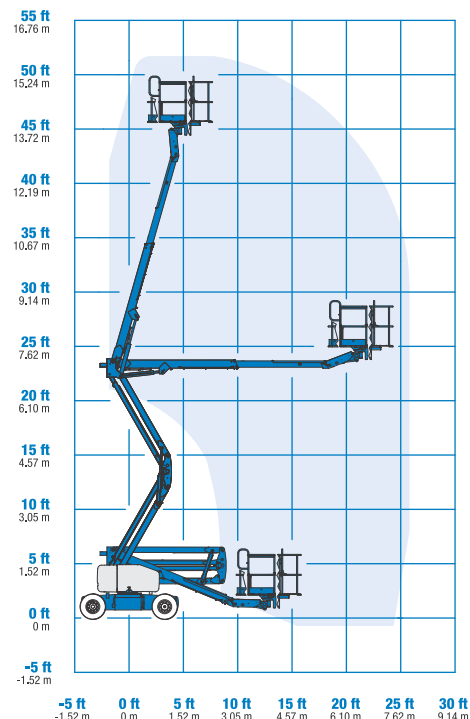

Range Of Motion Z-45/25J

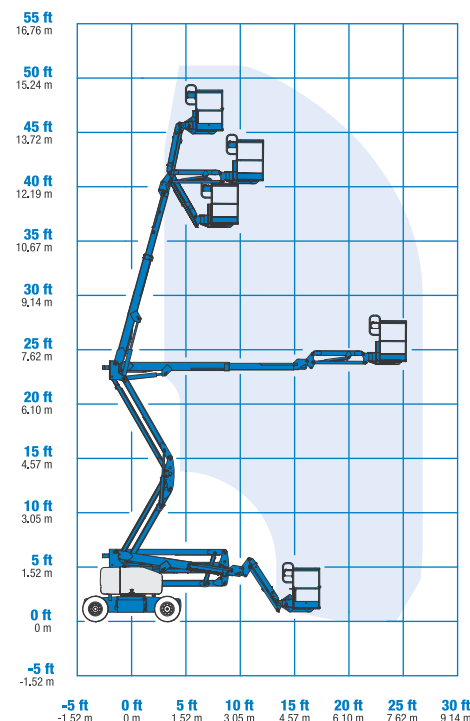



Self-Propelled Articulating Booms

Z™ -45/25 & Z™ -45/25J DC/Bi-Energy

Features

Standard Features

Measurements

Z-45/25

- 51 ft 6 in (15.87 m) working height
- 25 ft (7.62 m) horizontal reach
- 23 ft 1 in (7.04 m) up and over clearance
- Up to 500 lbs (227 kg) lift capacity

Z-45/25J

- 51 ft 9 in (15.94 m) working height
- 25 ft 1 in (7.65 m) horizontal reach
- 22 ft 1 in (6.73 m) up and over clearance
- Up to 500 lbs (227 kg) lift capacity

Productivity

- Self-leveling platform
- Hydraulic platform rotation
- Fully proportional controls
- Thumb rocker steer
- Drive enable
- AC power to platform
- Horn
- Hour meter
- Tilt alarm
- 355° non-continuous turntable rotation
- Zero tailswing

Power

- 48V deep cycle battery pack
- 24V DC auxiliary power
- On board alternator powered by Tier IV Kubota 13.3 hp (9.9 kW) engine (Bi-energy model only)
- Battery charge indicator-BCI (Bi-energy model only)
- Universal 30A battery smart charger

Easily Configured To Meet Your Needs

Platform Options

- Steel 6 ft (1.83 m) (standard)
- Steel 6 ft (1.83 m) tri-entry

Jib Options

- Non-jib
- Articulating 5 ft (1.52 m) jib boom

Power

- 48V DC (eight 6V 350 Ah batteries)

Drive

- 2WD

Tire Options

- Industrial foam-filled (standard)
- Industrial non-marking foam-filled

Options & Accessories

Productivity

- Platform swing gate
- Half-mesh platform inserts with swing gate
- Platform top auxiliary rail
- Air line to platform
- Fire resistant hydraulic oil
- Biodegradable hydraulic oil
- Aircraft protection package*
- Tool tray
- Fluorescent tube caddy
- Pipe cradle (pair)
- Alarm package
- Panel cradle package**
- Work light package
- Lockable platform control box cover
- Tow package

Power

- AGM batteries
- EE UL583 Fire Protection rating (DC only)
- Battery charge indicator-BCI (DC only)
- Low voltage interrupt with BCI
- Cold Weather Package (Bi-Energy only)
- 800 watt inverter (DC only)
- Diesel catalytic muffler (Bi-Energy only)

